

TILLERPILOT 1600 & 2500

INSTALLATION & OPERATING INSTRUCTIONS

INTRODUCTION

Navico Tillerpilots 1600 and 2500 have been developed after extensive sea trials in varying types of craft and conditions at sea. The equipment incorporates many unique features for improved performance and trouble free operation.

Marine grade materials and high spec components are used throughout. A tiller pilot is a valuable crew member and we therefore recommend storage in a dry environment when not in use to prolong optimum performance and long life.

Both models are totally self-contained automatic tiller pilots and incorporate a motor, electronic servo circuitry, gearing, push rod and novel micro-electronic compass.

The difference between the 1600 and 2500 is in the linear drive mechanism, the latter being an extremely high efficiency recirculating ballscrew, offering greater thrust and faster actuator travel from lock to lock.

Both autopilots have a stainless steel rowlock which slots into a brass socket (provided). The brass socket should be installed permanently (fixed with grp resin or epoxy resin) 19" (480mm) to starboard of the cockpit centreline. (See separate paragraph for port hand installation). When mounted in the operational position ensure that the automatic pilot is horizontal and at right angles to the tiller, when it is amidships.

The push rod is connected to the tiller via a stainless steel ball headed pin. The pin should be sited along the centreline 18" (460mm) from the rudder stock or pintle.

Position the system a minimum of 30" (750mm) from the yacht's steering compass.

Porthand Installation: If a more rigid site for fixing the rowlock pin is on the port side or if the tiller configuration is such that it impedes full travel of the actuator arm when mounted to starboard, porthand installation can simply be carried out by rotating the label on top of the compass through 180° and when adhere securely when replaced.

CAUTION: An automatic pilot is a very valuable extra member of the crew. It does not, however, automatically avoid danger. Always keep a vigilant lookout.

INSTALLATION PROCEDURE

- 1) Take measurements and mark preferred position as shown in Fig.1.
- 2) Ensure that the automatic pilot will be horizontal when in the operational position and that the push rod reaches the centre of the tiller. If not, refer to the paragraph on installation accessories.
- 3) ROWLOCK CUP On the starboard side of the cockpit (or port side if the compass label has been rotated through 180°) drill a $\frac{1}{2}$ " (12.7mm) hole in the side of the cockpit. Ensure that the thickness of the cockpit is at least the same depth as the rowlock socket, if not, reinforce the underside with hard wood or marine grade plywood. Finally fix the rowlock socket in place with epoxy resin.

NOTE: Tillerpilots are very powerful devices and very high loads can be exerted therefore a very strong bond is essential.

- 4) TILLER PIN. If the push rod sits directly onto the centre-line of the tiller, drill a $\frac{1}{4}$ " (6mm) hole, insert the stainless steel tiller pin and secure with epoxy resin. If the push rod is too high, too low, or requires extension refer to the paragraph on installation accessories.

When secured, the shoulder of the tiller pin should project $\frac{1}{2}$ " (12.5mm) above the tiller.

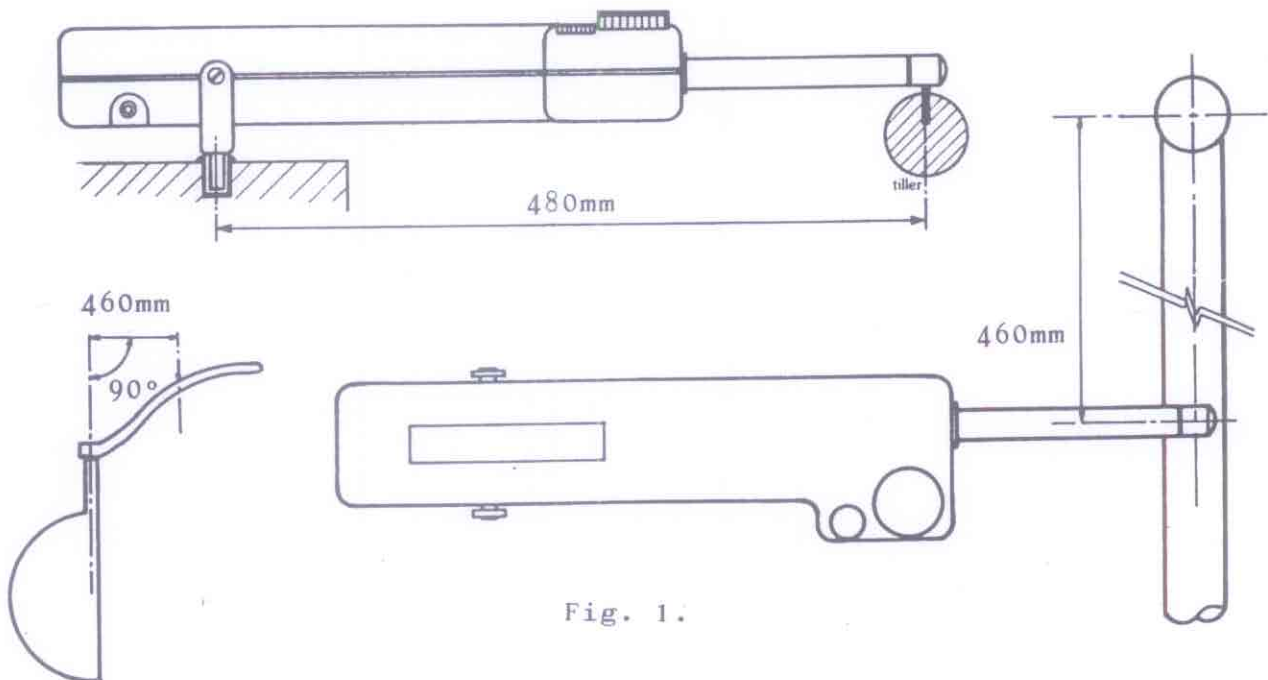

Fig. 1.

INSTALLATION (Cont'd)

- 5) **POWER CONNECTION.** A waterproof plug and socket is provided. The socket should be installed as close as practicable to the automatic pilot and the unit's own power lead shortened to suit. Connect wires to plug and socket. The BROWN LEAD is POSITIVE and the BLUE LEAD is NEGATIVE.

The unit is protected by a 5amp fuse located in a fuseholder on the underside of the unit.

If the unit is accidentally connected to the ship with reverse polarity, then the fuse will blow. A spare is provided for replacement.

INSTALLATION ACCESSORIES

- 6) **PUSH ROD EXTENSIONS** If, due to the width of the cockpit the most convenient or the strongest siting position for the rowlock cup is further than 19" (480mm) from the centre of the tiller arm, extension rods can be added to the push rod. These are available in six lengths:- 30mm (1.3/16"), 60mm (2³/₈"), 90mm (3¹/₂"), 120mm (4³/₄") 150mm (6") and 300mm (12").

The push rod extension is simply fitted by unscrewing the black end plug, screwing in the extension rod and replacing the end cap onto the end of the push rod extension.

- 7) **TILLER ATTACHMENT/PEDESTAL MOUNTS** On vessels where the tiller height is not adjustable and the height of the automatic pilot requires raising or it is preferred to lower the mounting attachment on the tiller, the following two types of installation accessory are available. Pedestals are manufactured in three sizes:- 30mm, 60mm and 90mm. Tiller brackets are manufactured in four sizes:- 30mm, 60mm, 90mm and 120mm.

CANTILEVER BRACKET. A Cantilever bracket is also available for mounting on side of cockpit; 135-240mm.

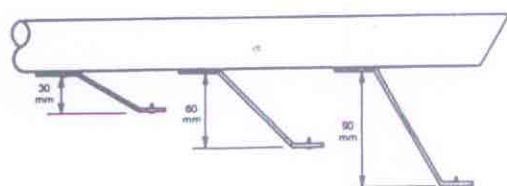
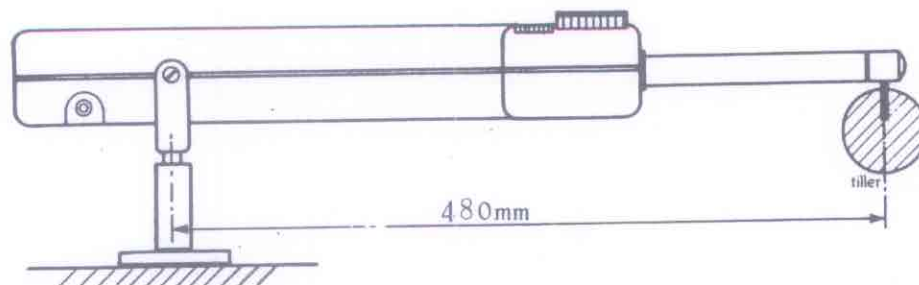

Tiller Bracket

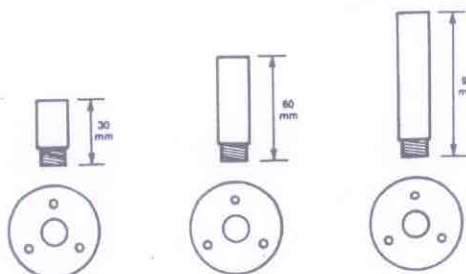

Pedestal Mountings

CONTROLS

- 8) Navico Tillerpilots have a compass dial plus two basic controls - a mode/rudder ratio switch and a variable sea state knob.

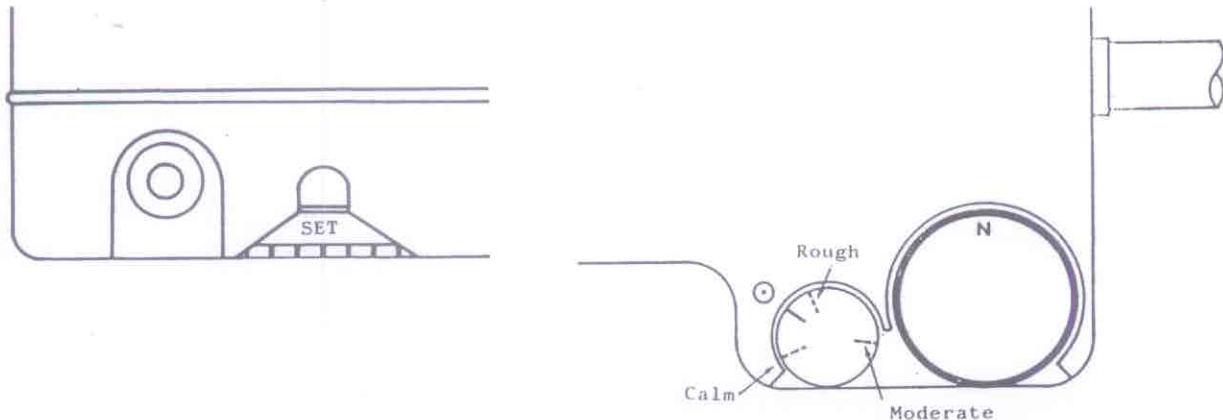

- 9) Mode/Rudder Ratio - This switch, located next to the Windvane socket, is positioned at "SET" to facilitate alignment of autopilot compass with ship's head and to position actuator end cap over tiller pin. When operating in the autopilot mode one of four rudder ratios (amount of rudder movement given to compensate for a fixed amount of off course error) can be selected.

Generally, the same setting is used most of the time (this setting being found by sea trials) but on occasion it may be necessary to increase the rudder movement.

NOTE: The effect of too little rudder ratio can be observed by the vessel being predominantly knocked off course to one side and taking a long time to return to desired heading.

Too much rudder ratio results in oversteering and a pronounced 'S' shape course.

CONTROLS (Cont'd)

- 10) Sea State: This control located next to the compass dial, adjusts a deadband which prevents over active performance of the autopilot and hence conserves battery power. This is set according to prevailing weather conditions. Fully anti-clockwise is for the roughest of seas, fully clockwise is for calm weather. Periodic adjustments to this control may be necessary as conditions change on a passage.
- 11) Compass Dial: Rotatable through 540° (1½ turns), this is used to align the autopilot onto the ship's heading. It should be noted that due to magnetic deviation, a discrepancy between the autopilot's and ship's compass may exist. Slight discrepancies between the two are of no significant importance and once aligned to the ship's heading the autopilot will maintain a good course.

The compass dial on top of the Tillerpilot should be aligned approximately with north of the ship's steering compass.

- 12) Weather Helm: A very important feature of Navico Tillerpilots which differentiates them from other autopilots at corresponding prices is that they incorporate automatic application of weather helm. This ensures that the set course will be maintained irrespective of change in balance of the yacht that may occur during the course of a passage.

OPERATION

- 13) It is suggested that sea trials be carried out in calm uncongested waters. A short time should be allowed to familiarize oneself with the effect of all controls.

Use of the Navico Tillerpilots 1600 and 2500 is straightforward:

- i) Manually steer the desired course.
- ii) Align compass dial with ship's heading.
- iii) Rotate mode switch from off to "SET" position.
- iv) Align actuator end cap over Tillerpilot pin by small movements of the compass dial (clockwise retracts actuator, anti-clockwise extends actuator).
- v) Push actuator end cap onto the tiller pin and select desired rudder ratio (position 1, 2, 3 or 4).

Small changes of desired course may be made using the compass dial. However, it is recommended to take up new headings (over 40° difference) by repeating the operating procedure. This allows correct weather helm to be applied instantaneously.

OPERATION (Cont'd)

Once grasped, this procedure will become second nature. However, it should be noted that violent movements of the compass dial, by hand, can result in the actuator overshooting. In the "SET" mode, the actuator will settle in a position of no movement when aligned to the ship's heading. This position can be moved anywhere along the length of actuator stroke.

(Rotation of the compass dial causes the actuator to move, returning it to the original position stops it).

This is a very useful function as it enables the autopilot rudder reference signal to include the weatherhelm required to balance any offsets.

The sea state control, also functions whilst the Tillerpilot is in the "SET" mode and controls the width of deadband for the actuator to settle in. It is important to position the sea state control (deadband) to suit prevailing weather conditions when initialising Tillerpilot into the "SET" mode.

WINDVANE

- 14) For long windward passages, a windvane is a great asset. A socket with rubber bung is fitted to accept an optional windvane attachment.

The windvane is purely electronic and requires no complicated cords to operate the feedback mechanism. Ask your dealer for further information.

When the windvane is not in use always ensure that the rubber bung is in position to prevent ingress of moisture.

REMOTE CONTROL

- 15) An optional hand remote unit is available which also plugs into the windvane socket. This allows port or starboard helm to be applied from a distance of 7 metres. A very useful accessory when negotiating moorings or a harbour entrance.

HINTS UNDER SAIL

- 16) For a comfortable and fast passage, it is always recommended to pay careful attention to sail trim. Your Tillerpilot will enable you to attend to this task especially when sailing single handed. Sailing your vessel badly out of balance will result in your automatic pilot having to work unnecessarily hard, thereby causing excessive drain on your batteries.

HINTS UNDER SAIL (Cont'd)

If your yacht is sailing out of balance in gusting conditions she may luff up suddenly to windward. When sailing manually, the helmsman automatically counteracts this by applying sufficient weatherhelm to maintain the desired heading. Although Navico Tillerpilots incorporate an automatic weatherhelm circuit, this has been designed to compensate for gradual changes to standing helm that typically occur during a passage due to varying wind conditions.

This automatic compensation circuit may take approximately one minute to restore the yacht onto its original heading after a change in helm balance has occurred.

To enable your autopilot to steer the straightest course, especially in gusting conditions, it is important to pay careful attention to sail balance. This may necessitate reefing the mainsail more than you would expect to when sailing manually.

The power and speed of the Tillerpilot 2500 should be capable of handling sensibly canvassed yachts up to 14m in all but the worst of conditions. Caution is, however, given when running down wind especially in a following or breaking sea. Sailing by the lee or with the wind dead astern should be avoided in extreme conditions as your automatic pilot cannot anticipate the size or power behind the next wave. Whenever possible, especially in bad weather, sail with the wind 30° towards the be

Sailing under autopilot is a most enjoyable experience, especially on long passages. Do not, however, fall into a false sense of security. Always keep a vigilant look out. Your Tillerpilot does not automatically avoid other shipping or a sandbank.

Happy Cruising!

SERVICE

- 17) Other than the occasional smear of vaseline over the power supply plug and around the windvane socket, there is no need for servicing. All moving parts are lubricated for life at the time of manufacture.

Tillerpilot is guaranteed for 12 months from date of retail sale. If it is ever necessary to have the unit repaired, return it carriage paid (in its original packing case) to the agent in the country of original purchase with a copy of the receipted invoice showing date and place of purchase.

IMPORTANT : Special tools and test equipment are required to set up and align both compass and feedback system. Warranty will be invalid if the outer case is opened by any person other than an appointed service engineer.

Navico operate a policy of continual development and reserve the right to alter, end and improve their range of products.